

Verb Semantics and Double Object Constructions

A constraint-based approach to Double Object Constructions in German

Dorothee Beermann

NTNU, Trondheim / Stanford University

dorothee.beermann@hf.ntnu.no

Abstract:

This paper treats verbs of diverse syntactic and semantic origins that enter into preposition-less double object constructions in German. It develops a fine-grained semantics within a lexicalist approach to grammar. Three semantic components are recognized: **situation schemata** which represent situational knowledge in the form of a matrix of abstract participant constellations; the attribute **designated participant**, within the nucleus specification of verbs, which insures linking to subject, independent of thematic entailments, and finally a **proto-role representation of thematic information**. These semantic components are integrated by means of an attribute-value representation of verb meaning. Three main ditransitive situation types, namely TRANSITIONS, PERTINENCE RELATIONS and INDUCTIONS are introduced. These semantic situation types allow us to capture the semantics of a variety of ditransitive meanings within a system of ditransitive situation-types. Through an account of diathesis alternations in terms of ‘**additive phrasal build-up**’, the notion of **construction** is given an independent status within an HPSG style build-up of the grammar.

Introduction

The success of a grammar that treats the projection of ditransitive verbs in terms of constructions, depends not least on the question whether we can identify a unique ditransitive semantics that corresponds to such a construction type. In this paper I will show that TRANSFER, a concept which is often believed to represent the ‘core-meaning of ditransitive verbs’, is strangely at odds with what we see as the actual array of meanings expressed in German ditransitive constructions. Not only does German allow four different ditransitive subcategorization-frames, in addition also transitive verbs can, by adding a so-called free dative, relatively freely appear in what looks like a ditransitive frame. I will argue that so-called free datives should be classified as arguments – though not as arguments of the verb, but as arguments of the construction as such. Given that ditransitive constructions can include transitive verbs also transitive verbs need to be interpretable within a ditransitive meaning paradigm. It follows that a ditransitive semantics suitable for these constructions must apply to verbs of diverse syntactic and/or semantic origins and that it therefore needs to satisfy

different constraints than a ditransitive semantics that is designed for a particular class of verbs.

In section one, I will argue that TRANSFER is not an adequate concept for the meaning of ditransitive constructions. Although the arguments of verbs within this construction type can express concepts that are generally associated with Agent, Beneficiary/Recipient and Theme, these labels are still not representative for the semantics of the constructions as a whole. I will propose that verbs that enter into ditransitive constructions are semantically united, in that they realize what one might call a **'ditransitive situation schema'**, by which I mean a basic relational constellation between the three participants of a ditransitive situation. The notion 'ditransitive situation schema' is introduced in section 2. My main goal is to show how situation schemata can be used to represent seemingly incompatible verb meanings as rooted in one common situation type. I develop a feature-based account of verb meaning that unites situation type information and thematic information, and thus allows a more fine-grained representation of verb meaning than generally assumed. Verb semantics is subsequently encoded in a hierarchy of ditransitive situation types with three main subtypes, TRANSITIONS (section 3), PERTINENCE RELATIONS (section 4) and INDUCTIONS (section 5).

Section 6 discusses the mapping constraints necessary to accommodate the type of verb semantics suggested here. In particular, I propose two revisions to standard HPSG linking constraints. Firstly, the four grammatical functions, SUBJECT, DIRECT OBJECT, INDIRECT OBJECT and OBLIQUE replace the VALENCY attribute, and secondly, I suggest that phrases, in addition to verbs, can select arguments. I propose to loosen the Argument Realization Principle, which is part of the linking constraints assumed in an HPSG-grammar, to allow for cases of argument realization where the arguments of the head are properly included in the set of arguments licensed by the phrase it projects.

In section 7, I will look more closely at diathesis alternations connected to ditransitivity. I will outline the idea of a **'transitive-headed' ditransitive phrase** which is an application of the containment version of the Argument Realization Principle suggested in section 6. I will then sketch a sign-based model of how a ditransitive phrase can be projected from a transitive verb to form a ditransitive construction.

Throughout this work I present semantic information as part of verbal signs, using Head-Driven Phrase Structure Grammar (HPSG) (e.g. Pollard & Sag 1994 and Sag & Wasow 1999) as our theoretical reference point. Ideas expressed here are further influenced by work in Construction Grammar (e.g. Fillmore 1994 & Goldberg 1995), and embed the concept of Proto-Roles, best known from Dowty's work on lexical semantics (1991).

1. German double object constructions and their meaning - a short survey.

I start with a short clarification concerning my terminology.

I would like to refer to something in the meaning of ditransitive verbs/constructions that unites them, and that is crucially involved in their 'mapping' to a ditransitive syntactic frame. I will call this something 'ditransitive semantics'. I will furthermore use the expression 'double object frame' or 'ditransitive frame' to refer to the purely syntactic properties of ditransitive constructions. In my understanding of the notion 'ditransitive construction', I follow Fillmore (1999), who informally defines a 'construction' as a phrasal linguistic object with phonological, morpho-syntactic and semantic properties. To my mind ditransitive constructions are a set of related constructions, within a wider paradigm of interrelated constructions featuring a secondary object in addition to a direct one.

I now turn to the semantics of ditransitive verbs proper. I believe that the most conspicuous difference between the semantics of English and German ditransitive constructions arises from the types of verbs that can be used in double object frames. Next to verbs of *material transfer*, German allows a rich variety of 'ditransitive' verbs that semantically have little or nothing in common with what one would subsume under the notion of TRANSFER. I will first illustrate this point with verbs from the dominant DAT>ACC pattern, and then with verbs from the three smaller patterns. I will also consider transitive verbs that enter into ditransitive constructions.

1.1 Semantic Variety and Theta theory

Not only *geben* 'to give' and *senden* 'to send', which some scholars understand as the prototypical ditransitive verbs (e.g. Goldberg (1995) and references therein), but also the verbs listed under (1) are part of the large group of DAT>ACC ditransitive verbs:

- (1)a Er hatte seinem Sohn(DAT) die Party(ACC) erlaubt.
 He hadhis son the party permitted
He had given his son permission to have the party.
- b Ralf hat seinem Kollegen(DAT) die Stelle(ACC) gegönnt.
 Ralf has his colleague the position not begrudged
Ralf didn't begrudge his colleague the position.
- c Man kann dem Wein(DAT) den Alkohol(ACC) entziehen.
 One can the wine the alcohol drain
It is possible to drain wine of its alcohol content.

Erlauben 'to permit' in (1a) expresses situational control, *gönnen* 'to not-begrudge' ((1b)) expresses situational-attitude and *entziehen* 'to drain' ((1c)) describes a part-whole relation between its complements. Semantically distinct, the verbs in (1) seem only united by the fact that their individual meanings are **not** associated with the assumed standard meaning of ditransitive verbs. Yet, since they also express their arguments in a double object frame, they are at least syntactically as much ditransitive in nature as *geben* and *senden*, the German correspondence of 'to give' and 'to send'. (1) is thus a first illustration of the discrepancy between the assumed 'standard' ditransitive meaning and what we see as its actual array.

I believe that this discrepancy is significant, and therefore should be reflected more adequately in the semantics of ditransitive verbs. I would like to start my argumentation with a short review of what is generally associated with the notion 'ditransitive semantics'.

One common property of, in particular, research on English ditransitive verbs, is that verb meaning is directly translated into a set of theta roles corresponding to the number of arguments a verb can have. Either as a cluster concept as in work by Foley and van Valin (1984) or Dowty (1991), or as the traditional unique individual labels, theta roles are meant to capture the main semantic components expressed by the nominal arguments of verbs. The general perception of how semantic information can 'map' or 'link' to the actual grammatical representation is encoded in the concept of a Theta Hierarchy or through a general constraint such as Dowty's Argument Selection Principle (Dowty 1991).

In recent work on ditransitive verb semantics such as Goldberg (1995), the core meaning of ditransitive constructions is identified as *successful transfer* between a *volitional agent* and a *willing recipient*. Goldberg claims that ‘give’ represents the ‘*conceptual archetype*’ for ditransitive constructions which expresses the meaning ‘CAUSE-RECEIVE’. The three theta-roles identified by her, are Agent, Recipient and Patient.

We already saw for ditransitive verbs of the DAT>ACC paradigm in German that they not necessarily express TRANSFER or even anything remotely related to CAUSE-RECEIVE. Thus, subjects of verbs like gönnen ‘not to begrudge’ ((5b)) or *erlauben* ‘to permit’ ((5a)) are not the classical Agents (nor are they Causers), to the extent that this notion entails some involvement of the agent-bearer in the event described. Instead, it is attitude or situational control that is expressed. *Erlauben* e.g. expresses volition but not agentive involvement on the part of the individual associated with the subject. With respect to the verb *entziehen* ((5c)) as in ‘*drain wine of its alcohol content*’, it is in turn the semantics of the two objects that fails to confirm with the standard varieties of ditransitive theta patterns, such as Recipient/Goal/Beneficiary - Theme/Patient.

But not only verbs within the DAT>ACC frame are at odds with the theta labels that are intended to characterize the semantics of their arguments. Verbs of the three smaller valency-groups add with their meanings to the semantic diversity within the ditransitive paradigm. Consider (2).

- (2)a Man hat den Anwalt(ACC) des Verbrechens(GEN) angeklagt.
 one has the lawyer the crime accused
The lawyer has been accused of the crime.
- b Sie hatten die Kinder(ACC) der Kälte(DAT) ausgesetzt.
 they had the children the cold exposed
They had exposed the children to the cold.
- c Ich würde immer das Bier(ACC) dem Wein(DAT) vorziehen.
 I would always the beer the wine prefer
I always would prefer beer to wine.

Also with respect to (2) one can not help but notice that what the so-called ‘ditransitive core-verbs of *material transfer*’ and ditransitive verbs such as *anklagen* (6a) or *aussetzen* (6b) do not form a semantic class within any of the standard class-inventories.

There is however one possible reservation against treating the verbs of the three smaller double object patterns as authentic ditransitive verbs, which I will briefly address.

We saw that the verbs of the type listed in (2) are not associated with the main DAT>ACC ditransitive frame, and moreover, in the case of (2a) do not even contain a dative object. It is therefore reasonable to ask, whether these verbs should rather be kept separate. So, perhaps verbs of the three smaller valence classes are not only morpho-syntactically distinct from the main class, but also semantically.

What speaks against such an assumption is the existence of verbs that seem to belong to one semantic class but are distributed over several syntactic frames. *Berauben* ‘to rob’, for example, which has a ACC>GEN frame, belongs semantically to the class of ‘*reversed-transfer*’-verbs, together with verbs such as *stehlen* ‘steal’ and *wegnehmen* ‘take from’. It is only *berauben* that selects a ACC>GEN frame, the latter two verbs select a DAT>ACC frame. If we make morpho-syntactic differences criterial for which verbs possess a ditransitive semantics, we would have to say that *berauben*, *stehlen* and *wegnehmen* fall into different semantic classes – something I would like to avoid¹.

A further example illustrating semantic unity across ditransitive valence classes is provided by the verbs *lehren* and *unterrichten*. Both verbs mean ‘to teach’, but while *lehren* follows an ACC>ACC pattern, *unterrichten* selects a direct object and a PP complement. Following the above reasoning, I will exclude none of the four morpho-syntactic instantiations from the set of ditransitive construction-tokens.

Back to our short survey of verbs that can enter into ditransitive-construction, and that resist a classification as verbs of Transfer, I next turn to diathesis alternations.

German transitive verbs enter relative freely into ditransitive constructions by licensing a so-called ‘free dative’.² Although I agree with the generally made assumption that

¹ I however do not exclude the possibility that the verbs within the smaller ditransitive valence patterns represent semantic sub-classes within an overall ditransitive paradigm to yet be developed.

² German grammarians often distinguish between ‘*Pertinenz-dativ*’, *dativus commodi*, *dativus incommodi* and *dativus ethicus*. Here we will treat all ‘free-datives’ as ‘phrasal arguments’. However, some restrictions apply to ethical datives. For an explanation of phrasal arguments see section 7.

these datives are not arguments of the transitive verb, I still would like to distinguish them from adjuncts, and say that these datives are arguments introduced by the ditransitive construction. In section 7, I will discuss this idea in detail. At this point I simply assert that also transitive verbs in construction with a free dative should be treated as instances of a ditransitive constructions.

So, let us consider the meanings of transitive verbs when construed in a double object frame. Consider the examples in (3):

- (3)a Wir müssen Anna(DAT) die Windeln(ACC) wechseln.
We have to change Anna's diapers
- b Man hat Dr.Kimble(DAT) die Frau(ACC) getötet.
 one has Dr. Kimble the wife killed
Dr.Kimble's wife was killed.
- c Mark hat meinem Bruder(DAT) die Hand(ACC) verletzt.
 Mark has my brother the hand hurt
Mark hurt my brother's hand.
- d Du must mir (DAT) nicht die Kinder(ACC) erschrecken.
 you must me not the children scare
You must not scare the children (so that it is to my disadvantage).

The indirect objects in (3) are not the standard Beneficiaries, in the sense that indirect objects of creation verbs are, illustrated in (4):

- (4) Er hat seiner Mutter (DAT) einen Kuchen(ACC) gebacken.
 he has his mother a cake backed
He has baked his mother a cake.

(4) states that he baked the cake with the intention to give it to his mother. In (3) on the contrary, intentionally is not presupposed. Moreover not all indirect objects of ditransitived transitive verbs can undergo lexical passivization, which seems only available to genuine Beneficiary participants such as indirect objects of creation verbs. This fact is illustrated in (5) and (6):

- (5) a *Dr. Kimble kriegt seine Frau getötet. (corresponding to 3b)
 Dr. Kimble becomes his wife killed
- b *Mein Bruder kriegt seine Hand verletzt. (corresponding to 3c)
 my brother becomes his hand hurt
- (6) Meine Mutter kriegt einen Kuchen gebacken.
 My mother becomes a cake baked

I conclude that not all of the indirect objects in (3) are classical Beneficiaries, instead they refer to an individual that is a second main participant, a notion that I will come back to in the following.

Summing up, I would like to draw the following preliminary conclusions:

- The notion of Transfer is not the core concept of ditransitive verbs.
- Ditransitive verbs are not *cause-receive* verbs.
- Although the arguments of ditransitive verbs can express concepts that are generally associated with Agent, Beneficiary/Recipient and Theme, these labels are not representative for the semantics of verbs that enter into ditransitive constructions.
- A desideratum is still that a ditransitive semantics suitable for ditransitive constructions should be able to describe the aspects of meaning shared by all verbs that enter into double object frames.

2.Ditransitive situations – a small semantic model

In the following sections I would like to suggest a modular approach to verb meaning within a feature-based approach to lexical semantics. What is generally referred to as a ditransitive situation is under present assumptions a cover label for several semantic components that will be identify in the following. I would like to suggest a general semantic constraint obeyed by all verbs entering into ditransitive constructions, but I will still distinguish three ditransitive situation types. These types will allow me to accommodate a wide array of ditransitive meanings.

2.1 The relational structure of ditransitive situations

I believe that it is part of the speaker/hearer's semantic competence to distinguish situation types through what one might call 'holistic situation schemata'. Such schemata represent basic constellations between the participants of a given situation. I furthermore think that a ditransitive situation is a situation type in which the two main participants – those expressed by the subject and the indirect object - are only **indirectly** related, be it through a prior or an ongoing course of action. Formally, 'indirectly related' means that the participants corresponding to subject and indirect object will never be construed as participants of the same sub-event within the ditransitive situation. The intuition behind this assumption is not easy to formulate. Roughly the impression is that the event expressed by a ditransitive construction is in a crucial ways 'tied up to' a second main 'actant' which is a second potential agent.

I will take two steps to express the above intuition in a linguistic model. I first present a small model, which describes a ditransitive situation schema as a disjoint set of possible constellations between participants and relations, and then I convert this model into an attribute-value representation, compatible with HPSG style grammars.

2.2 The structure of ditransitive situations

Starting with the term **situation**, I will assume that a situation is construed over both **participants** {A,B,C,...} and **relations** {R₀,R₁,R₃,...} as its arguments. The here relevant subtypes of 'situation' are EVENTS and STATES. I distinguish between two-place-(transitive) and three-place-(ditransitive) events and two-place states – where 'n-place' refers to the number of arguments. While participants are atoms, relations are not, and can take other relations as their arguments.

Under present assumptions, the array of possible combinations between participants and relations in ditransitive situations is restricted by a constraint called the Principle of Ditransitive Asymmetry. It is formulated below:

The Principle of Ditransitive Asymmetry

A and B, the main participants of a ditransitive event, expressed by SUBJ and IO respectively, can never stand in a direct relation to each other.

This principle claims that it is a basic property of ditransitive situations that A and B can never occur in a direct semantic relation, although they form, together with C, expressed by DO, the triangular relation which is characteristic of ditransitive situations. Given Ditransitive Asymmetry, we can describe ditransitive situations as a set of possible participant constellations. This is formulated in figure 2:

Figure 2 Ditransitive Matrix

R1 (A,C) \wedge R2 (B,C)
or R1 (A, R2 (B,C))
or R1 (R2 (A,C), B)

The matrix reads as follows: a ditransitive situation is a state of affairs in which its atomic participants A, B and C stand in either of the following three relations:

- A stands in a relation to C and B stands in a relation to C, or
- A stands in a relation to a relation between B and C, or
- B stands in a relation to a relation between A and C.

The claim is that the meaning of a ditransitive verb/construction can be partially described on the basis of the abstract constellations given in figure 2. To that end, I would like to turn these three relational constellations into properties of three situation types which I will for the time being call TYPE I, II and III ditransitive situation types, as show in figure 3:

Figure 3 Ditransitive Situation Types (DSTs)

TYPE I DST **[R1 (A,C) \wedge R2 (B,C)]**
TYPE II DST **[R1 (A, R2 (B,C))]**
TYPE III DST **[R1 (R2 (A,C), B)]**

From now on, the abbreviation ‘DST’ will be used for ‘ditransitive situation type’, and I will describe the three ditransitive types one by one.

3. TYPE I DST – TRANSITIONS

3.1 Characterizing ‘transition’ in a DST

Verbs of material and intellectual ‘transfer’, as well as verbs of ballistic motion, express Type I DSTs, that is to say, their meanings represent the first of the relational compositions defined in the ditransitive matrix in figure 2. Type I DSTs are TRANSITIONS³.

Take, for example, the verb *geben* ‘to give’. *Geben* implies that A initially ‘has’ C⁴. The verb describes a TRANSFER, which is a sub-type of a TRANSITION, as the result of which B ‘has’ C⁵. *Abnehmen* ‘to take from’ differs from *geben* in that it implies the opposite order of ‘have’-relations: here B ‘has’ C prior to A ‘having’ C. In the following we let R₁ refer to ‘A has C’ and R₂ to ‘B has C’.

TRANSITIONS in general can be characterized along the following main parameters:

(I) Mode of TRANSITION

The difference between verbs of material and intellectual transfer can be established along the parameter MODE by assuming that this parameter can be further subdivided into ‘Manner’ and ‘Medium’ as its constituents. Medium can be realized either as material or as intellectual transfer. Under Manner we can capture the difference between ditransitive verbs of ballistic motion⁶ and subclasses of verbs of material transfer such as *schicken* ‘to send’ *überreichen*

³ ‘Transition’ as well as other concepts when used to refer to a situation type will be written in capital letters.

⁴ “A has C”, that is R₁ and “B has C”, that is R₂ represents STATES which are sub-types of STATE OF AFFAIRS.

⁵ That B stands in a relation to C does not necessarily imply that B factually has C. Consider the following two examples:

- (i) Ich habe ihm das Packet geschickt, aber er hat es nie gekriegt.
I send him the package but he never received it.
- (ii) Jedem Kind wurde ein Ballon gegeben, aber nicht alle Kinder haben einen genommen.
Every child got a balloon but not all children took one.

⁶ German *ditransitive verbs of ballistic motion* optionally subcategorize for two objects. They are compounds of the preposition *zu* ‘to’ and the motion verb. *Ditransitive verbs of ballistic motion* are thus different from *transitive verbs of ballistic motion* as illustrated below:

- (i) Sara sollte (ihm) den Ball zuwerfen.
Sara was supposed to throw him the ball.

‘to present’ and *zustecken* ‘to slip’, and also *leihen* ‘to loan’, *spenden* ‘to donate’ and *vererben* ‘to bequeath’.

(II) Directionality

This parameter represents the contrast illustrated by *geben* vs. *abnehmen*. It is either the case that $R_1 \rightarrow R_2$ or that $R_1 \leftarrow R_2$, where the arrow represents the development of the event. In $R_1 \rightarrow R_2$, we will call R_1 the base state and R_2 is the state achieved through the transfer described by the verb. In the case that $R_1 \leftarrow R_2$, R_2 is the base state and R_1 is the result of the transfer. The latter case is realized by verbs such as *abnehmen* ‘to take from’ *rauben* ‘to rob’ and *entreissen* ‘to snatch from’.

(III) Actualization

This parameter will differentiate verbs of *intended transfer* from verbs of *actual transfer* (successful or not). In the former class we find verbs such as *versprechen* ‘to promise’ and *schulden* ‘to owe’, which we thus distinguish from verbs of *actual transfer*.

3.2 Representing TRANSITIONS as Attribute-Value-Graphs

To take our description of DSTs one step further, I first show how the ditransitive semantics considered here can be expressed through sign-based grammatical representations, and in particular within the type of feature structures used in Head-Driven Phrase Structure Grammar (HPSG). I do not have the space to introduce the HPSG formalism, and therefore have to refer the reader to the relevant literature (in particular Pollard & Sag (1994), and for an introduction, Sag and Wasow (1999)).

An HPSG sign consist of two main attributes (PHON and SYNSEM⁷), which represent phonological, syntactic and semantic information. Our main concern is semantic

(ii) Sara sollte (*ihm) den Ball werfen.
Sara was supposed to throw him the ball.

Ditransitive verbs of ballistic motion touch on a question that we cannot discuss in this context, namely the exact nature of the connection between their status as complex predicates (zu+V) and their ability to select a IO.

⁷ CONTEXT, the third attribute of a verbal sign is of no relevance in the present discussion .

information which is expressed in the CONTENT attribute under SYNSEM; in Pollard and Sag (1994), the information of a word SYNSEM is schematically of the following form :

Figure 4

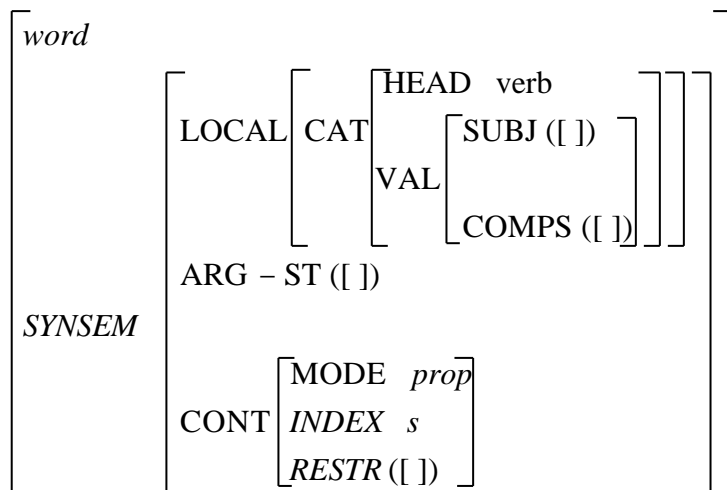

The locus for the situation-type information that we are concerned with is within the attribute RESTR (“semantic restriction”). I will use the intermediate attribute NUCLEUS, following Koenig (1999), Ginsburg & Sag (2000) and others to represent the semantic information of the type discussed here. Moreover, further developing a suggestion by Sag & Wasow (1999), I would like to represent grammatical functions directly as attributes,

replacing the VAL-feature, as outlined in figure 5; this, rather than the A(tribute)-V(alue) M(atrix) in figure 4, is thus our schema of a word SYNSEM (See section 6 for further discussion of our attribute ‘GF’):

Figure 5

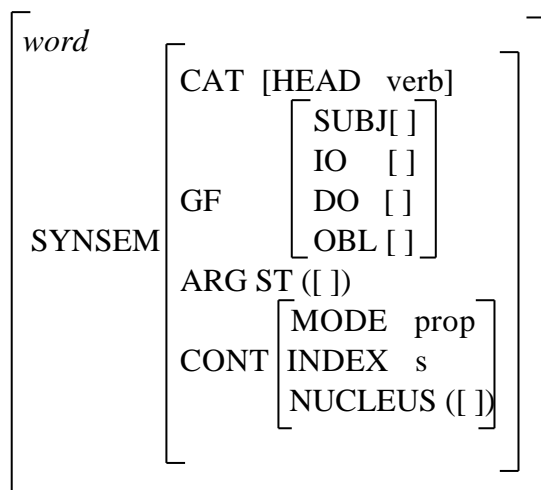

We now illustrate how TYPE I DSTs can be represented as an Attribute Value Matrix.

Consider Figure 6:

Figure 6 Partial description of the semantic nucleus of the verb 'geben' (first version)

<i>Transition</i>		
RELN1 [1]	<i>State</i>	
	GEBER	i
	GEGEBENES	k
RELN2	<i>State</i>	
	EMPFAENGER	j
	GEGEBENES	k
MEDIUM	material	
MANNER	by hand	
BASESTATE	[1]	
ACTUALIZATION		+

Figure 6 gives a relative straightforward translation of the previously discussed DST parameters, together with the relational information coming from the ditransitive constellation matrix, into an AVM-format. Participant roles as well as values of the attributes are resolved to represent the verb *geben*. Participants are indices, and mapping, although not shown here, will be done in terms of semantic indices. TRANSITION is a feature structure of the sort NUCLEUS, which means that AVM 6 is a possible value relative to the NUCLEUS attribute of AVM 5.

So far I have referred to the participants of ditransitive events as A, B and C (or as role labels relative to an individual verbs as in AVM 6). I will now consider more clearly the specification of RELN 1 and RELN 2 and their participants.

3.3 Proto-roles and thematic asymmetry

A question, hitherto left open, concerns thematic asymmetry. The reader will have noticed that I have called A and B main participants, assuming an asymmetry between these participants and the participant C. Moreover, my notation A and B seems to suggest that A is an Agent, B a Beneficiary while C is a Patient. However, nothing in the system developed here determines such a choice. On the contrary, I portray situations as complex entities composed of sub-relations. Although A and B are both participants in the same ditransitive situation, they by definition never occur in the same sub-relation. A and B are thus never directly ordered with respect to one another, and should therefore not be represented as elements on a mono-stratal hierarchical scale. But if not in a theta-hierarchy, how then can we represent thematic asymmetries?

To answer this question I will make use of Dowty's concept of proto-roles, however, embedded in a somewhat different system than the one Dowty suggests. Although I follow Dowty in assuming that proto-roles represent thematic properties, I will not adhere to his idea that proto-properties constitute a direct link between the verb's semantics and its argument selection. A 'linking rule', of the type formulated in Dowty's 'Argument Selection Principle' is hence a mechanism that I will not adopt. Here is now my proposal.

Central to Proto-role theory is the use of only two thematic role types that are sets of entailments relative to verbal predicates. For explicitness, I reproduce Dowty's list of entailments, and discuss then how they can be instantiated relative to DSTs.

Properties of proto-agents (Dowty's (27))

- a.volitional involvement in the event or state
- b.sentience (and/or perception)
- c.causing an event or change of state in another participant
- d.movement (relative to a position of another participant)
- e.exists independently of the event named by the verb

Properties of proto-patients (Dowty's (28))

- a.undergoes change of state
- b.incremental theme
- c.causally effected by another participant
- d.stationary relative to movement of another participant
- e.does not exist independently of the event , or not at all.

Dowty's (1991) calculus for ditransitive predicates is formulated in a corollary which states that the participant with the greater numbers of proto-patient properties will be assigned the direct object function while the second non-subject argument will become the indirect object. The present system of relative thematic role assignment makes stipulations of the type suggested by Dowty unnecessary. To that end, consider the two relational attributes of TYPE I DSTs, here for convenience reproduced in figure 7:

Figure 7

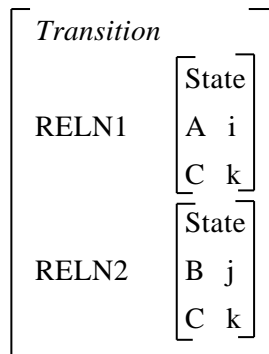

Figure 7 reproduces the relational skeleton introduced so far. For theta assignment we first consider RELN1⁸. The participant with the most Agent properties is assigned the Agent role. This will be A. C becomes the proto-patient by default⁹. We next consider RELN2 and

⁸ We could as well start with the evaluation of R2, as becomes clear immediately.

⁹ From Dowty's work it has not become clear to me if proto-role assignment is an independent or relational process, that is, given a proto-agent is found; will the other participant necessarily be a proto-patient or will the second argument be evaluated independent of the evaluation of the first? For reasons of economy, we will assume that the patient role is assigned by default after the proto-agent has been 'found'.

again evaluate its participant with respect to their proto-role properties. B will have more agentive properties. It will become the Agent relative to R2 while C becomes again by default the Patient.

One major problem, however, remains. I claim that A and B are both main participants and Agents relative to their situations, R_1 and R_2 , respectively, but although such an assumption captures the agentive properties of Beneficiaries¹⁰, it still is the case that only A will be mapped to subject while B will be expressed as indirect object. I can imagine two possible solutions to this problem: The first one is to think of theta assignment as a mechanism that **compiles** thematic properties relative to relations, in line with Dowty's proposal. This would only make sense if it would be the case that A-participants possess always more agentive properties than B-participants¹¹. This is however not necessarily the case. Take for example the verb *diktieren* 'to dictate'. The person that writes a letter seems to execute as much 'agentivity' as the one dictating it. Both participants can for example control the situation by their speed of dictating or writing. Even clearer, in the situation described by the verb *schulden* 'to owe', it is not really the participant expressed as subject that controls the situation. The agentive property of 'control' is with the Beneficiary. And yet the situation is still about the participant linked to the subject function. Not 'agentiveness' per se, or not even a crucial 'amount of it', necessarily determines the 'Aboutness' of the situation, and hence which one of the participants becomes subject. To capture this intuition, as our alternative to the 'compilation' approach, I will assume that it is an intrinsic property of verbs to determine a 'center' for the situation they describe. This 'situational center' is identical to the argument 'predicated of' by the verb.

I think of the verb's ability to determine a situational center as a lexical primitive, and assume accordingly that lexical entries of verbs are specified for their 'situational center'. In these terms A is always the situational center of a ditransitive verb. However, instead of using the term 'situational center', which could be misunderstood as a pragmatic term, I will use **designated participant** as the technical term for A. As the according attribute label I suggest DESIGPART.

¹⁰For a good review of the literature on agentive properties of Beneficiaries see (Goldberg 1995).

¹¹ and that the evaluation of R_1 and R_2 can be compared by the compiler.

I can now up-date the AVM for TRANSITIONS accordingly, generalizing from figure 5.

Figure 8 Partial description of TRANSITIONS (final version)

<i>Transition</i>								
RELN1 [1]	<table style="border-collapse: collapse; width: 100%;"> <tr> <td colspan="2" style="border-top: 1px solid black; border-bottom: 1px solid black; padding: 2px;"><i>State</i></td> </tr> <tr> <td style="padding: 2px;">PROTOAGENT</td> <td style="padding: 2px; text-align: right;">i</td> </tr> <tr> <td style="padding: 2px;">PROTOPATIENT</td> <td style="padding: 2px; text-align: right;">k</td> </tr> </table>	<i>State</i>		PROTOAGENT	i	PROTOPATIENT	k	
<i>State</i>								
PROTOAGENT	i							
PROTOPATIENT	k							
RELN2 [2]	<table style="border-collapse: collapse; width: 100%;"> <tr> <td colspan="2" style="border-top: 1px solid black; border-bottom: 1px solid black; padding: 2px;"><i>State</i></td> </tr> <tr> <td style="padding: 2px;">PROTOAGENT</td> <td style="padding: 2px; text-align: right;">j</td> </tr> <tr> <td style="padding: 2px;">PROTOPATIENT</td> <td style="padding: 2px; text-align: right;">k</td> </tr> </table>	<i>State</i>		PROTOAGENT	j	PROTOPATIENT	k	
<i>State</i>								
PROTOAGENT	j							
PROTOPATIENT	k							
DESIGNPART i								
MEDIUM medium								
MANNER manner								
BASESTATE [1]or[2]								
ACTUALIZATION boolean								

4. Type II DST – Pertinence Ditransitives¹²

Ditransitives of *situational attitude* and *conditioning*, as well as ditransitives with embedded part-whole relations, are Type II DSTs. They express the second relational composition taken from the ditransitive matrix given in section 3, here repeated as figure 10:

Figure 9

R1 (A, R2 (B , C))

TYPE II DSTs realize a relation between A and R₂. More specifically, they define PERTINENCE RELATIONS. By that we mean, that, different from for example CAUSATIONS, PERTINENCE RELATIONS connect the designated participant to a second situation although he does not directly cause or control this situation. If R₂ is a STATE between B and C, then it will be conceptualized as already existing in a temporal,

¹² The German term ‘Pertinenzdativ’ refers to one type of the so-called ‘free-datives’. Here the term PERTINENCE is used for a situation type and ‘free datives’ are under present assumptions phrasal arguments.

conventional or in a natural sense (part-whole relations) but at the same time crucially related to the designated participant. Verbs such as *wünschen* ‘to wish’, *gönnen* ‘not to begrudge’, *ermöglichen* ‘to facilitate’ as well as *versagen* ‘to deny’ are *pertinence* verbs.

I will first discuss general properties of *pertinence* verbs, and then turn to a sub-class expressing a part-whole relation between the two objects of the construction.

4.1 Properties of Pertinence Ditransitives

A common property of PERTINENCE DSTs is that the ‘designated participant’ ‘behaves’ towards an existing situation. Individual verbs within this class however differ with respect to the expressed degree of A’s ‘involvement’ into the State expressed by R₂. *Gönnen*, for example, describes A’s positive attitude towards R₂, while *ermöglichen* requires a certain degree of ‘involvement’ of A to make R₂ possible. We would like to describe this fact as a property of designated participants, and as one of the parameters of PERTINENCE DSTs. Used as attributes in an Attribute Value representation, the parameters of PERTINENCE RELATIONS are defined as follows:

Figure 10 *Parameters of PERTINENCE ditransitives*

Involvement: indicating differences in ‘involvement’ of the designated participant in R₂.

Polarity: indicating if A’s effect on R₂ is positive or negative, i.e. constitutional towards the existence of R₂ or not.¹³

RELN1: indicating the type of situation that R₁ represents

On the basis of the above description we can design a feature-based description of this class of DSTs.

¹³ Examples of PERTINENCE ditransitives with a negative polarity are *neiden* ‘to envy’ or *vermasseln* ‘to ruin’, as in (I):

(i) Er neidet/vermasselt Sara das Studium.
 He envies that Sara studies/He spoils Sara’s years at the University.

There is an issue of cross-classification between PERTINENCE RELATIONS and INDUCTIONS connected to this subclass of verbs. How should we for example semantically classify the ditransitive use of the verb *verderben*, as in

(ii) Er verdirbt Lin die Party.
 He spoils Lin’s Party/ the party for Lin.

Figure 11 Partial representation of the PERTINENCE RELATIONS

<i>Pertinence</i>		
DESIGPART	INDEX	i
	INVOLVEMENT	agentive
	<i>STATE</i>	
RELN1	PROTOAGENT	j
	PROTOPATIENT	k
POLARITY	boolean	

A feature description of TYPE II DSTs allows us a very straightforward account of the difference between the verbs *gönnen* ‘to not begrudge’, *ermöglichen*, ‘to facilitate’ and *versagen* ‘to deny’¹⁴. While for *gönnen* we will have the value *volition* for the attribute INVOLVEMENT, the INVOLVEMENT-value of *ermöglichen* will be *conditioning*. The verb *versagen*, on the other hand, will have the same agentive specification as *ermöglichen*, but a different polarity.

Pertinence-verbs enter into an interesting diathesis alternation which we would like to briefly mention at this point.

Except for *part-whole ditransitive verbs*, TYPE II DSTs allow the following diathesis alternation:

- (7)a Wir ermöglichen ihr(DAT), dass sie studiert.
We make it possible for her to study.
- b Ich wünsche dir(DAT), dass du einen ruhigen Urlaub hast.
 I wish you that you a quiet vacation have
I wish you a quiet vacation.

This sentence has the two interpretations given above. Under the first reading the sentence is interpreted as a PART-WHOLE PERTINENCE RELATION (Lin’s party) , under the second interpretation it represents an INDUCTION (the party for Lin).

¹⁴ We are aware of the apparent redundancy that lies in specifying DESIGPART for each of the three ditransitive verb-classes. In this work we will however not define a ditransitive super-type, which is the obvious locus for accommodating shared properties of DSTs such as information about the designated participant. The reason lies in problems that are addressed at the end of section 7.

(8)a Wir ermöglichen ihr(DAT) ein Studium(ACC).

(8)b Er wünscht ihm(DAT) einen ruhigen Urlaub(ACC).

The difference between (7) and (8) is that the verbs in (7) subcategorize for a sentential complement rather than a direct object. The subject of the sentential complement and the indirect object are referentially co-indexed thus referring to the same individual. The direct object of the sentential complement, if there is one, is identical to the direct object of the corresponding double object construction.

Semantically, these constructions seem to denote a subtype of a *PERTINENCE RELATION*¹⁵. So far we have only considered *pertinence-verbs* with an embedded STATE. But in principle nothing seems to prevent a more complex relation between B and C. In case of sentential complements, we would have to say that R₂ contains a second relation of the type PROPOSITION, which represents B and C as the main participants of a transitive event. The system suggested here allows relations to embed other relations, and hence can be extended to capture such valence alternations.

4.2 Part-whole DSTs

Part-whole PERTINENCE RELATIONS are expressed by verbs/constructions that express a part-whole relation between their two objects. (9) exemplifies this class:

(9)a Dieser Prozess entzieht dem Wein(DAT) den Alkohol(ACC).
This process drains the alcohol out of the wine.

b Ich habe meinem Bruder(DAT) den Daumen(ACC) verletzt.
I hurt my brother's thumb.

¹⁵ *Pertinence relations* and *transitions* cross-classify at this point. Verbs such as *versprechen*, 'to promise', *schulden* 'to owe' etc, which describe TRANSITIONS (*verbs of future possession* in Beth Levin's terms and here a situation type with a negative value of the ACTUALIZATION attribute) can undergo the same valence alternation as verbs that embody pertinence situations, see (I):

(i) Er verspricht ihm(DAT),[dass er(NOM) Anita(ACC) anruft].
he promises him that he Anita calls
He promises him to call Anita.

- c Er hat dem Kind(DAT) das Gesicht(ACC) gewaschen.
He washed the child's face.

The ditransitive verb *entziehen* ‘to drain’(as given in 9a), as well as the ditransitive construction use of the transitive verb *klemmen* ‘to pinch’(as given in 9b) and *waschen* ‘to wash’ are *part-whole pertinence verbs*¹⁶. This verb class is partially described in figure 12

Figure 12 Partial description of a PART WHOLE PERTINENCE DITRANSITIVES

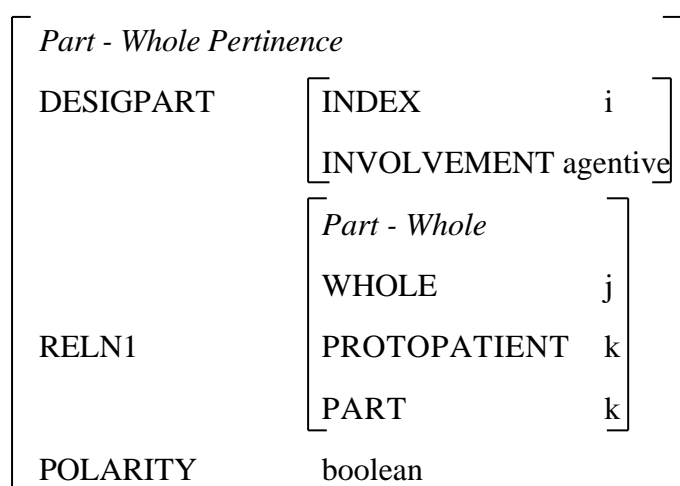

Notice that RELN1 contains three main participants rather than, as would be expected on the basis of (9), two participants. While the proto-agent of RELN1 (i.e., the indirect object) is directly identified as WHOLE, the proto-patient is identified as the part only via co-indexation with the value of a third participant labeled PART. Justification for this representation comes from constructions such as the one given below:

- (10) Er hat ihm den Ball an den Kopf geworfen.
He has thrown him the ball at the head.

¹⁶ Ditransitive constructions with a PART-WHOLE PERTINENCE semantics are also discussed by Abraham (1995) who suggests that the phrase expressing ‘the part’ is an adjunct to the indirect object expressing ‘the whole’.

In (10) the indirect object still represents the ‘whole’, but the ‘part’-concept is syntactically realized as a prepositional adjunct. Semantically, however, we would like to say that the prepositional phrase realizes a third semantic core relation that we have called PART. In constructions like (10), PROTOPATIENT (*der Ball*) and PART (*ihm*) are not co-indexed, but represent independent participants.

5. TYPE III DST - INDUCTIONS

The inductive ditransitive situation type is exemplified in (11) and its relational configuration is reproduced in figure 13:

- (11)a Er hat die Touristen(ACC) einem Sturm(DAT) ausgesetzt.
He exposed the tourists to a storm.
- b Er hat den Patienten(ACC) einer Operation(DAT) unterzogen.
He has submitted the patient to an operation.
- c Man hat dem Bauern(DAT) alle Rinder(ACC) getötet.
All the farmer's cows were killed.
- d Ich kann dir(DAT) das Rad(ACC) reparieren.
I can repair you the bike.
- e Der Sturm hat uns(DAT) die ganze Habe(ACC) verschlungen¹⁷.
The storm has devoured all our belongings.

Figure 13

R1(R2 (A, C) , B)

¹⁷ Compare (i) with (18):

(i) *Er hat mir das Steak verschlungen.
 he has me the steak eaten

(i) is ungrammatical. Yet, when we reconstruct the same sentence as a PART-WHOLE-PERTINENCE RELATION, it becomes quite acceptable:

(ii) Er hat mir **mein** Steak verschlungen.

Interestingly, such a semantic shift is not possible for the verb *essen* ‘to eat’, see (iii):

(iii) *Er hat mir mein Steak gegessen.

This contrast might be rooted in semantic blocking, caused by the more specific verb *wegessen* ‘to eat away’ which provides the intended interpretation of (iii), namely (iv):

(iv) Er hat mir mein Steak weggegessen.
He has eaten up my steak.

Inductions are situations where a third participant is intentionally or unintentionally ‘drawn into’ an event initiated by the designated participant. Ditransitive verbs with an oblique object, as well as transitive verbs can describe this situation type; however introducing an important semantic difference. Inductions expressed by the ditransitive verbs (*aussetzen* ‘to expose’ and *unterziehen* ‘to submit’¹⁸) describe a situation where B is exposed to a situation embodied by the oblique argument. Using the verb *aussetzen*, it is not possible to say that one has exposed the children to a book, or a parent. Neither one of these nouns can function as an oblique with respect to *aussetzen*. Nominal phrases that can however co-occur with *aussetzen* are for example *Leben in Armut* and *Erziehung der Eltern*, so that it is possible to use the verb *aussetzen* to say that the children have been exposed to life in poverty and the parent’s education.¹⁹ Equally the verb *unterziehen* has to select an oblique argument that directly expresses or refers to an event. Relating these observations to the relational constellation representing inductions, we want to say that C refers to an event. For transitive verbs, on the other hand, C represents a proto-patient type participant. To capture this distinction, I suggest INDUCTION-A, with C being a event (figure 14) and INDUCTION-B (figure 15), with C as a proto-patient, as subtypes of INDUCTIONS:

Figure 14 Partial semantic description of INDUCTION DSTs of type INDUCTION-A

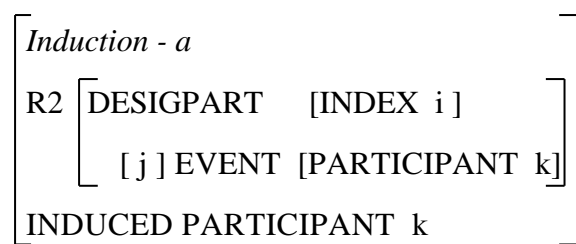

In figure (14) three participants of the ditransitive event are indexed as i, j, and k. The index j will be linked to the oblique. Its semantics is given as an event which has as its only participant the induced participant, the participant that will be linked to the direct object.

¹⁸ Not all ditransitive verbs in the ACC>DAT pattern express INDUCTIONS. *Vorziehen* ‘to prefer’ expresses a symmetric relation between the two objects. Symmetric verbs are not discussed here.

¹⁹ It is certainly possible to use nominals such as *Gefahr* ‘danger’ with *aussetzen*, where *Gefahr* refers to a situation that is dangerous. Another example is *Sonne* ‘sun’, describing a situation where someone is exposed to sunlight. Notice that *Mond* ‘moon’ cannot function as oblique here, unless it was full-moon and there is a typical situation going along with that.

Figure 15 Partial semantic description of INDUCTION DSTs of type INDUCTION-B

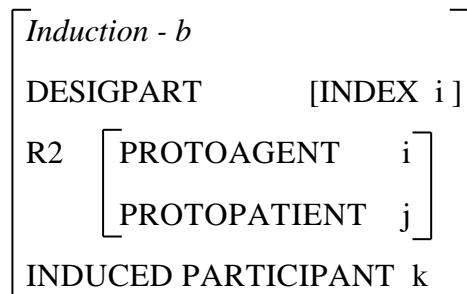

Transitive events can become ditransitive in meaning by ‘having an effect on’ or ‘be directed towards’ a third participant, given in figure 15 as the induced participant. Although German is permissive in which verbs can enter into ditransitive constructions, certain restrictions apply. Verbs of *manner of communication* generally can not enter into ditransitive constructions, as illustrated in (12), where *brüllen* ‘to shout’ exemplifies the pattern for the class. Other verbs within the same class are *flüstern* ‘to wisper’, and *murmeln* ‘to murmur’ etc :

- (12) *Er hat mir(DAT) einen Befehl (ACC) gebrüllt.
 he has me an order shouted.

The question, which semantic types of transitive verbs can enter into ditransitive constructions is beyond the scope of this paper, we can, however, indicate one essential restriction on ‘ditransitivation’. To this end consider the following contrast:

- (13a) Du erschrickst mir(DAT) die Kinder (ACC).
 ??You scare me the children.
- b *Die Kommentatoren befürchten uns(DAT) eine Recession(ACC)
 The commentators fear us a recession

The contrast between the grammatical (13a) and the ungrammatical (13b) seems to be rooted in the fact that *erschrecken* ‘to scar’ selects an ‘Agent- subject’ while *befürchten* ‘to fear’ asks for an Experiencer -subject.

That the distinction between Agent- and Experiencer-subjects is crucial is supported by the fact that verbs like *beschreiben* ‘to describe’ support DSTs while verbs like *sehen* ‘to see’ or *bedenken* ‘to think about’ do not:

- (14)a Er beschreibt ihm(DAT) den Weg (ACC).
 He describes him the way
He described the way to him.
- b *Er sieht/bedenkt ihm (DAT) den Weg (ACC).
 he sees/thinks him the way²⁰

Again, the difference between the verb in (14a) and (14b) is, that the former has an Agent-type subject while the latter selects an Experiencer-subject. To embody this distinction in a feature description, I suggest to type R₂ as a agentive event whereby the role ‘protoagent’ will stand for the required semantic role *Agent* as opposed to *Experiencer*. Figure 16 represents the description of the semantic nucleus of verbs describing inductions for the subtype INDUCTION-B, replacing figure 15:

Figure 16 Revised semantic description of INDUCTION DSTs expressed with a type INDUCTION-B

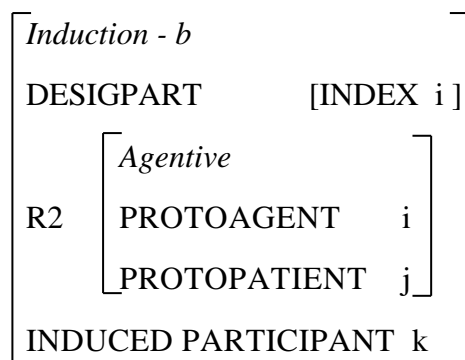

Having reached the end of this section, I would like to point out that the situation type INDUCTION is not restricted to two-place events. Also intransitives can be construed with

²⁰ What is however grammatical is the following:
 (i) Ich denke mir eine Zahl zwischen eins und zehn.
I think about a number between one and ten.

It then seems that an Experiencer subject in a ditransitive construction is only possible when the third participant and the designated participant are co-indexed.

respect to a second main participant, giving rise to a whole sub-class of productive diathesis alternations such as:

(15)a Sie wird (mir) krank.
She falls sick on me.

b Fido rennt mir weg.
Fido runs away from me.

Notice that (15a) and (15b) are different syntactic construction. (15a) contains, with the pronoun, a so-called ethical dative which necessarily is speaker centered and cannot be replaced by a nominal, while the dative in (15b) seems to be licensed by the directional particle *weg* ‘away’ and remains unrestricted with respect to its categorial status²¹. But although (15a) and (15b) are syntactically different, I think that the semantic analysis given for INDUCTION type ditransitive constructions can with minimal amendments also accommodate the semantics of intransitive constructions construed with an indirect object(cf. figure 26 below), thus capturing the perceived parallelism.²²

In this last and the preceding two sections, I have suggested a feature-based representation of three different situation types represented by verbs that enter into double object constructions:²³ TRANSITION, PERTINENCE-RELATION and INDUCTION. Ultimately these types, together with their sub types, (we discussed TRANSFER and PART-WHOLE PERTIENENCE RELATIONS, TYPE A and B INDUCTIONS) should be representable in an Inheritance Hierarchy for DITRANSITIVE SITUATION TYPES, of the form suggested in figure 17:

²¹ While (i) is ungrammatical, (ii) is not, thus illustrating the above mentioned categorial restriction ethical datives:

- (i) *Er wird seiner Mutter krank.
he becomes his mother (DAT) sick
(ii) Fido rennt seinem Besitzer weg.
Fido runs away from his owner.

²² A full discussion of the construction type exemplified in (15) is beyond the scope of this paper. I cannot formulate a precise analysis of it as a counterpart to figure , and I also cannot argue the perceivable merits of such an analysis versus one that construes the patterns in (15) as small clause configurations.

²³ Our study is not based on a survey of all ditransitive verbs in German, which is one of the reasons why we do not claim that the situation types that we have discussed here represent a comprehensive description of ditransitive situation types related to an NP, NP syntactic frame. The class of symmetric verbs, such as

Figure 17

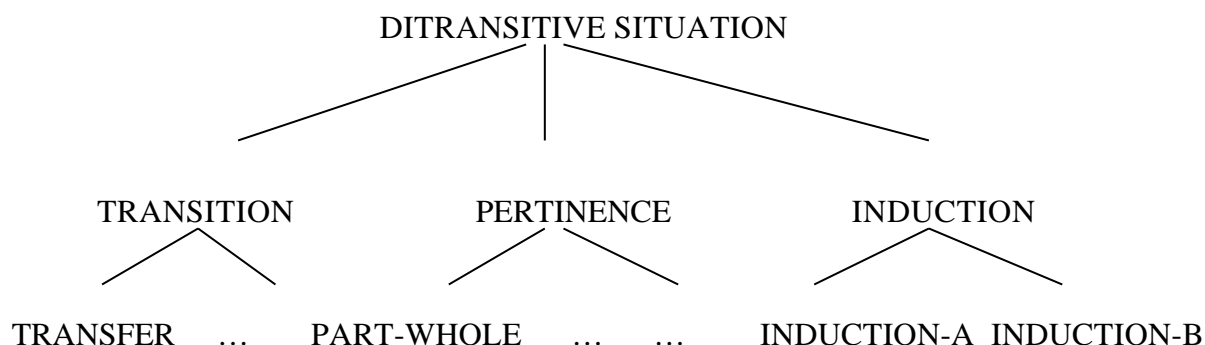

In considering figure 17 the reader will notice that we have not discussed the nature of the root-type, here labeled as DITRANSITIVE SITUATION. The root type is the obvious locus for the encoding of properties that pertain to all ditransitive sub-types, which makes for example the feature DESIGPART, introduced in the preceding sections, a good candidate for a root attribute. What however withstands at this point a feature-based definition of the root type, is the way in which ditransitive meaning was set up to begin with. I have suggested that what is characteristic of ditransitive situations, is that their two main participants can never stand in a direct relation to each other. If A is part of a sub-relation R, then B is not. Ditransitivity is thus formulated as a negative entailment, which I feel is hard to express within the declarative set-up of the attribute-value denotation.

In the following section, I will turn to ‘linking’ and discuss the theoretical constructs needed to map the different ditransitive situation types to a preposition-less double object frame

6. The Mapping between Syntax and Semantics

I start this section with a short presentation of the morpho-syntactic properties of German double object constructions.

vorstellen ‘to introduce’ or *vorausgehen* ‘to precede’ or *vorziehen* ‘to prefer x over y’ for example has not been discussed at all.

It is a well-known fact about German grammar that a double-object frame can have four distinct shapes, which differ in their linearization, as well as in the morphological marking of direct and indirect object. The following patterns are possible:

Figure 18 *German argument linearization and morphological case*

NOM>DAT>ACC
NOM>ACC>DAT
NOM>ACC>ACC
NOM>ACC>GEN

As is common, the symbol ‘>’ in (1) stands for ‘precedes’, and NOM, DAT, ACC, GEN are the standard abbreviations for the three cases nominative, accusative, dative and genitive. Although complement order is relatively free in German, linguists generally agree that German verbs are specified for a base order of their arguments, an assumption that is shared here. Also widely acknowledged is the fact that case marking and grammatical function are not isomorphic in German. An indirect object can be an NP morphologically marked as dative or accusative (although the latter is the ‘exception’²⁴), while an NP marked as dative can be an indirect object or an oblique object, and possibly also an adjunct²⁵.

It is not important **how** we label the different NPs – so a system different from the one I am about to introduce here might eventually be more adequate²⁶. Crucial is only that we have a consistent way of relating NPs to grammatical functions, since it is the latter construct that will play an essential role in our approach to mapping. So let me first summarize my essential assumptions and then go through some diagnostics:

²⁴ An example is:

(i) Wer hat die Kinder(ACC) das Lied(ACC) gelehrt?
Who taught the children the song?

²⁵ I am thinking in particular about constructions with a ditransitive verb plus an ethical dative such as (i)

(i) Gib mir(DAT) ja dem Mann(DAT) das Geld zurück.
give me PART the man the money back

These constructions are imperative in nature and the ethical dative is necessarily referentially-bound to the speaker (see also Draye 1998)

²⁶ For different suggestions within HPSG see e.g. Heinz & Matiassek (1994) and Przepiórkowski, A (1999). See also Molnárfi (1998)

I will make the following assumptions:

- German has direct, indirect and oblique objects
- Indirect objects as well as oblique ones can be morphologically marked as datives.
- Arguments in German are linearized according to their grammatical function.
- From left to right we observe the following pattern of argument linearization:

SUBJ > INDIRECT OBJECT > DIRECT OBJECT > OBLIQUE.

As the decisive diagnostic to support these assumptions, I will use structural and lexical passivization. Under structural (or standard) passivization, German indirect objects do not agree with the passive auxiliary *werden* ‘to become’ although they naturally occupy what looks like the subject position²⁷. Lexical passivization, also known as *kriegen/bekommen*-passivization, on the other hand, is only possible for indirect objects^{28/29}, but not oblique datives, as is shown in (16) and (17):

(16)a Er hat ihr(DAT) ein Buch geschenkt.
He has given her a book (as present).

b Sie(NOM) bekommt ein Buch geschenkt.

²⁷ Examples are:

- (i) Den Kindern (DAT,PL) wird(3,SG) geholfen.
The children were helped.
- (ii) Ihr(DAT,3sg,fem) werden(PL) die Ferien gegonnt.
her was the holidays not begrudged

²⁸ There is some disagreement about the unity of ‘single dative’ objects and datives in double object constructions based on different grammaticality judgment concerning the *kriegen/bekommen* passivization of single datives such as the one illustrated in (I):

- (i) Er kriegt geholfen.
He was helped.

For the author such examples are grammatical. For further discussion of this point see e.g. Kathol (1999).

²⁹ Not all indirect objects can undergo *kriegen/bekommen* passivization. Indirect objects that are part of a ditransitive construction with a PERTINENCE semantics (for explanation of this notion see section 4) for example:

- (i) Man hat ihm die Beförderung gewünscht.
One has wished him the promotio.

cannot undergo lexical passivization:

- (ii) *Er kriegt die Beförderung gewünscht.

Also INDUCTION type ditransitive (section 5) resist lexical passivization, except those derived from verbs of creation:

- (iii) Er bekommt einen Kuchen gebacken.
He got a cake baked.

I believe that this restriction is due to the meaning of the verbs *kriegen* and *bekommen*.

She was given a book (as present),

- (17)a Sie hat den Patienten der(DAT)Operation unterzogen.
She has submitted the patient to the operation.

b*Die Operation bekommt den Patienten unterzogen.

From the examples above, I conclude that the datives exemplified in (17) represent a grammatical function different from those datives that are indirect objects. I will call the datives exemplified in (17) oblique objects, or obliques for short. In addition, I will categorize genitive NPs, which are selected by verbs, as oblique objects, and thus generalize over the ACC>DAT and ACC>GEN patterns as both being of the type (DIRECT OBJECT > OBLIQUE)³⁰, thus allowing preposition-less double object constructions without indirect objects. On the basis of the above distinctions, we can now consider all four subcategorization patterns given in figure 18 and relate NPs and grammatical functions in a systematic way. The four sample sentences in (18) are displayed in the form of a matrix in Figure 19:

- (18)a Sie hat ihr(IO) das Buch(DO) geschenkt.
She has given her the book (as a present).
- b Er hat sie(DO) dem Sturm(OBL) ausgesetzt.
He has exposed her to the storm.
- c Sie hat die Schüler(IO) das Lied(DO) gelehrt.
She has taught the students the song.
- d Man hat ihn(DO) des Verbrechens(OBL) beschuldigt.
One has accused him of the crime.

³⁰ Notice that in the present system a syntactic class of verbs does not need to correspond to one situation type. While we classified *aussetzen* 'to expose' and *unterziehen* 'to submit' (both verbs with a ACC>DAT frame) as INDUCTIONS), *beschuldigen* 'to accuse' describes a PERTINENCE situation (the latter has a ACC >GEN frame).

Figure 19 Relation between Valence Frames and Grammatical Function

	SUBJ	IO	DO	OBL	verb
NOM>DAT > ACC	Sie	ihr	das Buch		geschenkt
NOM>ACC > DAT	Er		sie	dem Sturm	ausgesetzt
NOM>ACC > ACC	Sie	die Schüler	das Lied		gelehrt
NOM>ACC > GEN	Man		ihn	des Verbrechens	beschuldigt

Two interesting observations can be made with respect to figure 19. As already mentioned above, a double object construction in German does not necessarily refer to the sequence of an indirect and a direct object, but might also consist of a direct object and an oblique. Secondly, the linear order of the realization of the grammatical functions is preserved throughout the four different valence patterns for ditransitive verbs. The subject will always precede the indirect object, which in turn precedes the direct object. The latter will precede any oblique, if present. Modulo the presence of an auxiliary, which intervenes between the subject and the complements, the array of lexical entries in figure 19 represents in each instance a well-formed embedded sentences of German. It then seems that it is a constraint on the order of grammatical functions that determines the linearization of arguments in German, and therefore should be used to determine the order of elements on the ARG(ument) ST(tructure) list of a verbal sign. So, let us next reconsider our version of a verbal sign, given as figure 20 below, which is a reproduction of figure 5, used earlier in the discussion:

Figure 20

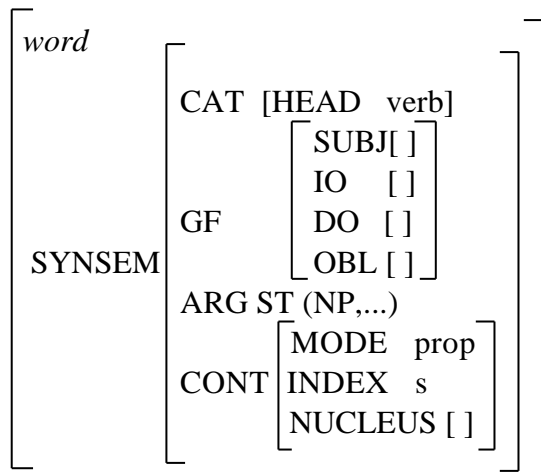

The elements on the ARG ST-list represent the arguments selected by the verbal head and are generally ordered according to an obliqueness hierarchy reflecting standard assumptions about Thematic Hierarchies. It has become clear from our discussion that we do not believe in individual theta labels and consequently also not in an order thereof. The fact that an IO precede a DO in German cannot be restated as ‘Beneficiaries precede Patients’, since the semantic relations embodied by indirect objects cannot successfully be characterized as Beneficiaries, as argued at length in the preceding sections.

Instead of using obliqueness, I suggest to use ordering of grammatical functions as the constraint on German argument linearization. Consequently, the ARG ST- list of the verb *geben* ‘to give’ takes the form of figure 21, while the ARG ST-list of the verb *aussetzen* ‘to expose’ takes the form of figure 22. Although elements on the ARG-ST-list are SYNSEMs, I will represent arguments by category labels with case as subscripts to not further complicate the picture:

Figure 21 ARG-ST < NP_{NOM}, NP_{DAT}, NP_{ACC} > (*geben*)

Figure 22 ARG-ST < NP_{NOM}, NP_{ACC}, NP_{DAT} > (*aussetzen*)

Following standard practice, I will use semantic indices to indicate linking. Summarizing, the approach to linking assumed here is given in figure 21:

Figure 23 Partial description of 'linking' for the verb 'geben'.

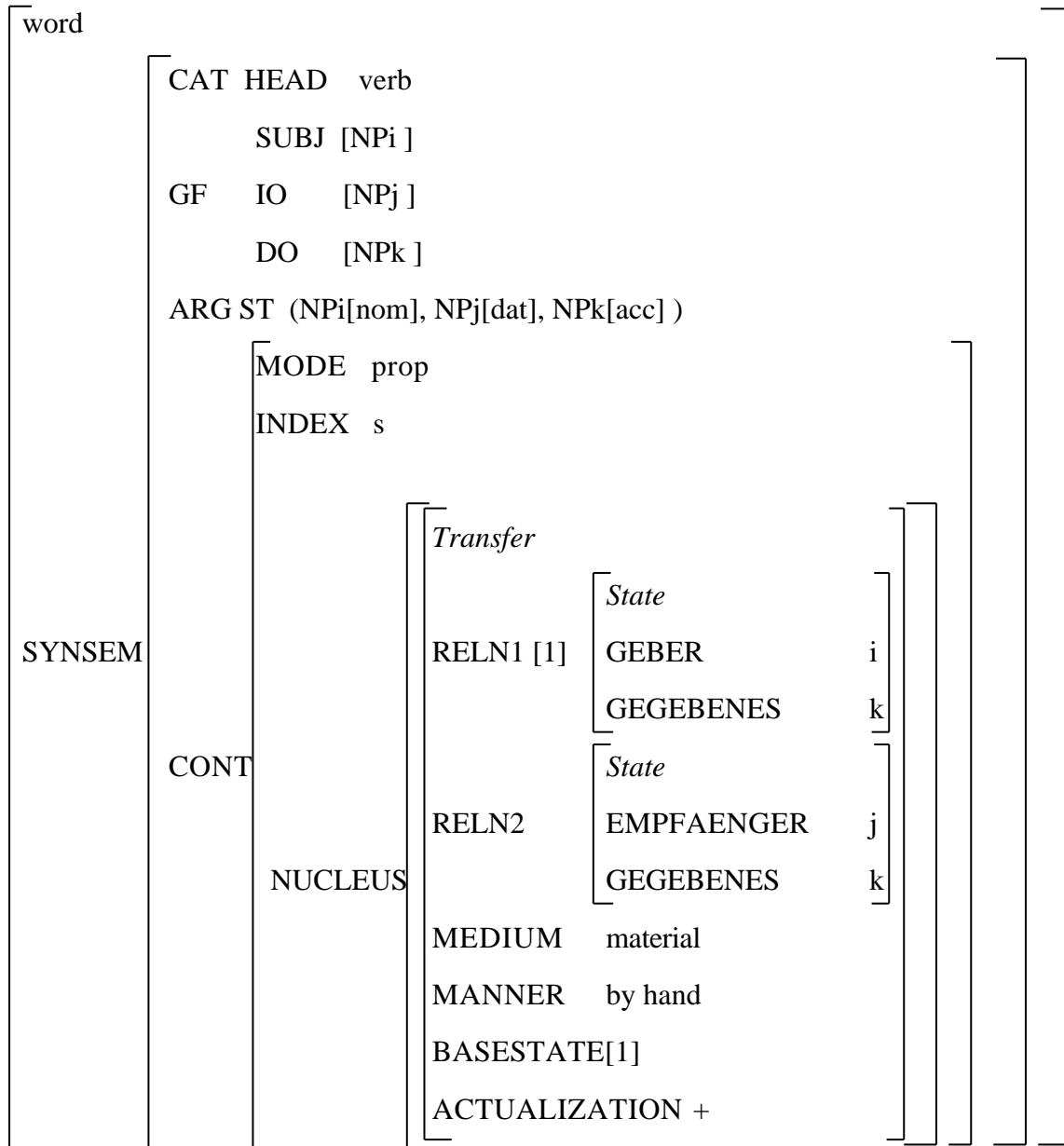

So far I have not given an account of how transitive verbs should be represented syntactically when part of a ditransitive construction. This is the topic of the our last section.

7. 'Transitive-headed' ditransitive phrases

The question we are asking in this final section is how syntactically and semantically transitive verbs can enter into ditransitive constructions. Or to put this question somewhat

differently, how is it possible that transitive heads can project ditransitive phrases? Consider the schematic tree representation in figure 24 of example (11c) repeated here as (19)

- (19) Man hat dem Bauern(DAT) alle Rinder(ACC) getötet.
All the farmer's cows were killed.

Figure 24

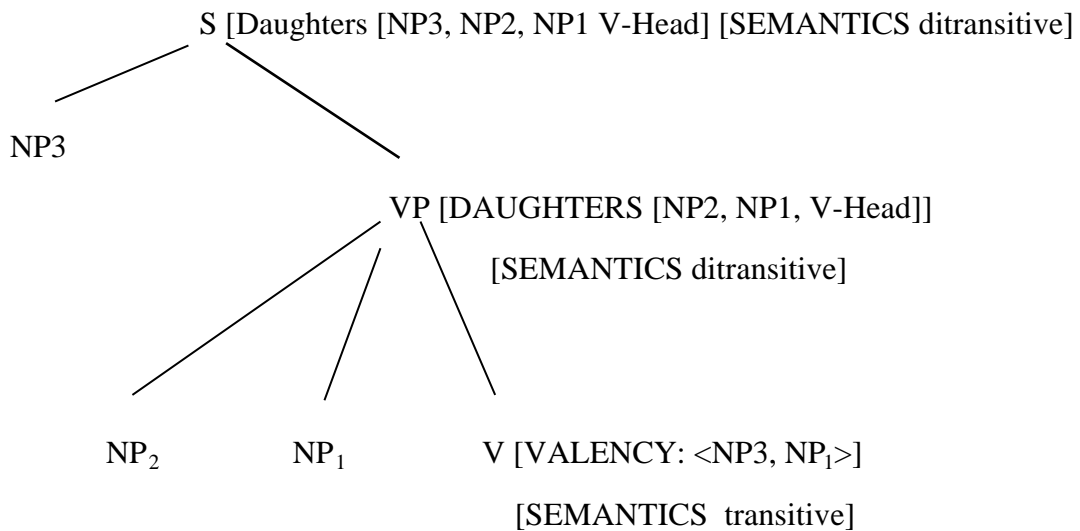

In ditransitive constructions with a transitive head, as depicted in figure 24, only NP₁ is selected by the verb. The second NP, that is NP₂, the so-called ‘free dative’, seems to be added in the build-up of the phrase. Moreover, the verb in isolation expresses a transitive situation, that is, a direct relation between the ‘subject’ and the ‘direct object’, but the phrase it projects describes a ditransitive situation.

One standard way to deal with such a phenomenon is to perceive it in terms of valence change, which in lexicalist grammars can be expressed by lexical rules. Thus a ditransitive lexical entry for the verb can be derived from a transitive one. The ditransitive construction can then be fully ‘projected’ from the syntactic and semantic specification of the verb.

I would like to pursue a somewhat different idea here, and allow phrases to introduce their own dependents, as well as add meaning. Phrases hence can introduce argument-like constituents not directly licensed by the verb, and add meaning components residing elsewhere than in the head. This is, of course, very much in the spirit of Construction

Grammar. Here I will represent this idea in terms of an HPSG- style phrasal sign to make it more precise. We start from the verbal word-sign. So, consider the feature description of the transitive verbal head:

Figure 25 Partial description of the transitive head of an additive ditransitive phrase

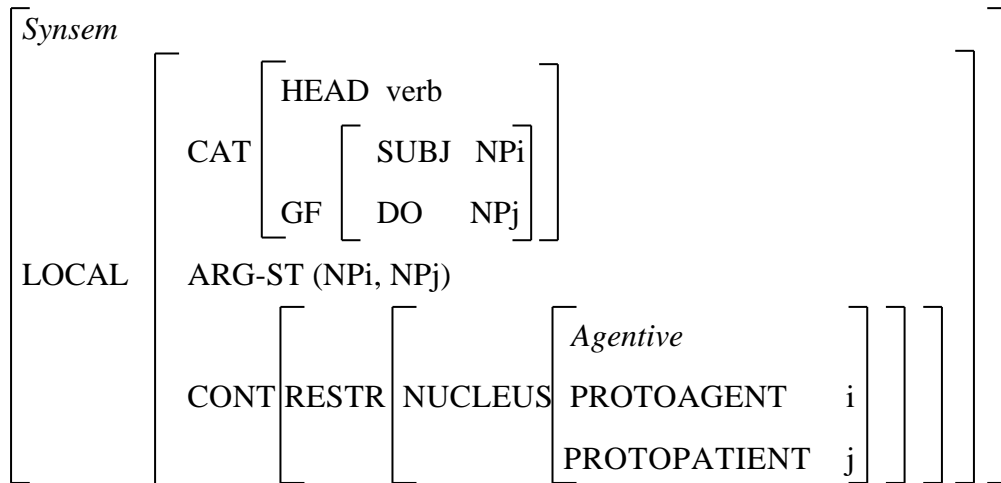
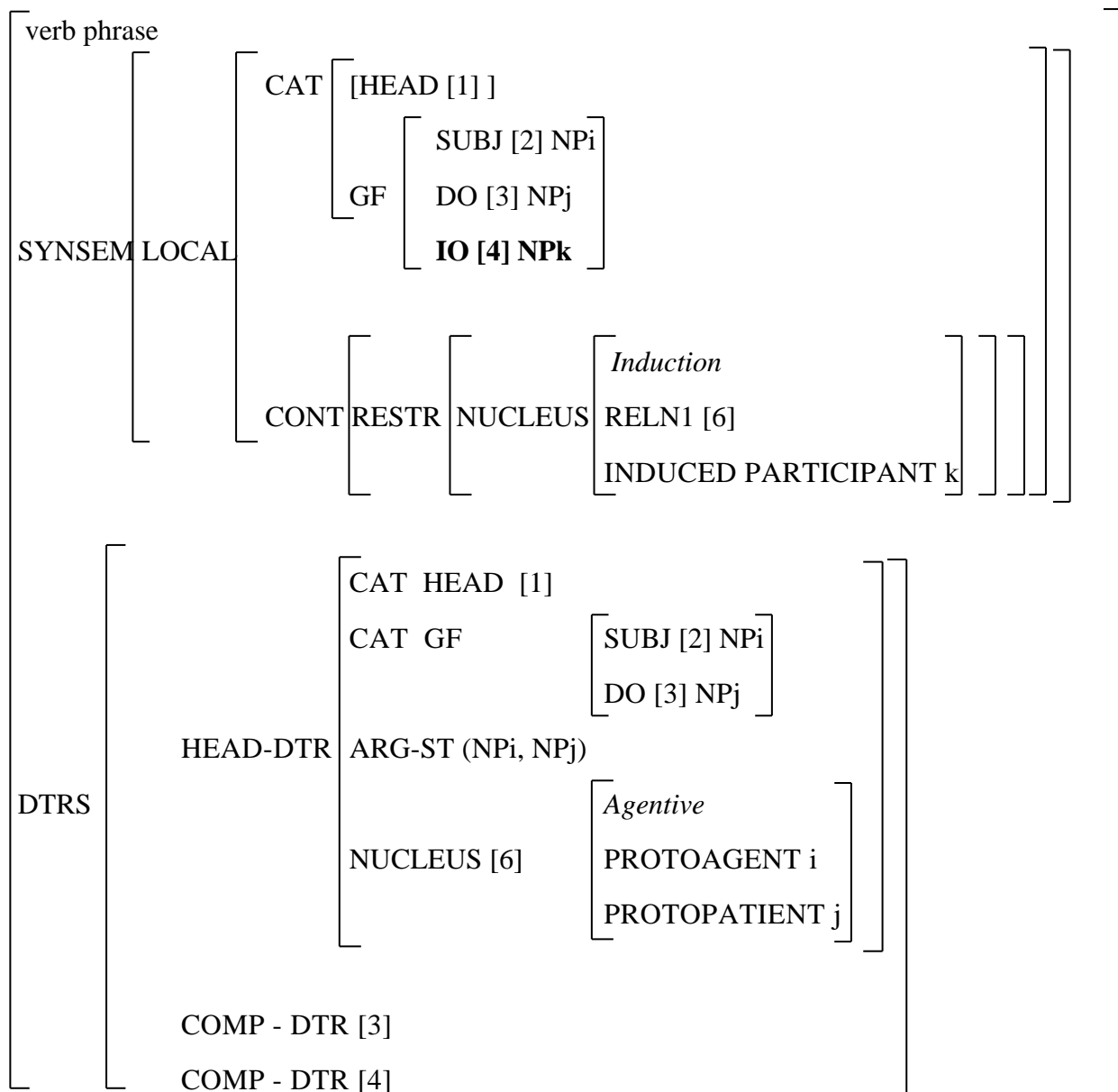

Figure 25 shows that transitive heads of ditransitive constructions do not differ from other transitive verbs. Particular to the present presentation of verb meaning, figure 25 reflects the semantic type of the verb as the value of the NUCLEUS attribute, whose type has been determined as AGENTIVE. My suggestion is that 'syntactic additivity' of phrases can be represented by projecting the argument-frame of the *head* as properly included in the argument specification of the phrase. For the 'semantic additivity' of the phrase, I suggest that the semantic specification associated with the *head*, is a proper part of the semantic specification of the phrase. Such a design is represented in figure 26:

Figure 26 *Partial description of an ‘additive phrase’*



Here, the semantic specification of the head (identified by the tag ‘[6]’) is structure-shared with the situational argument RELN1 of the phrase’s nucleus attribute. The interpretation of ‘construction meaning’ given here, is thus that the meaning of the verb is properly contained in the meaning of the phrase, justifying the characterization of this construction as ‘additive phrasal build-up’. Moreover, the GF specification of the phrase, reproduced in figure 27 for convenience:

Figure 27

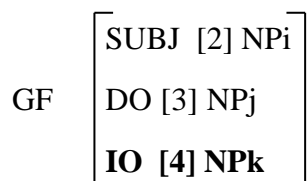

contains as a proper part the GF specification associated with the head (under the attribute HEAD-DTR)³¹. Notice that the GF-attributes used here are not subject to cancellation. In this respect, the GF attribute differs from the VAL (“valence”) attribute in HPSG³².

I briefly summarize. Ditransitive constructions with transitive verbs as their heads are in the literature mostly captured in one of the following two ways. Either the indirect object is perceived as some sort of a free adjunct (thus keeping the lexical specification of the verb constant), or the verb is claimed to have undergone a lexical valence change that allows it to license the additional indirect object. Here I have suggested a third way that allows us to introduce the indirect argument as well as the ditransitive meaning of the construction as a property of what I have called ‘**additive phrases**’. Further research will show if this notion can be developed as a sub-type of the type ‘phrase’. Work on a phrasal inventory for interrogative phrases by Ginzburg & Sag (2000) seems to be a promising step in the right direction.

8. Conclusion

In this paper I have suggested to capture the meaning of verbs that enter into ditransitive constructions by means of a modular approach to their semantics. I have recognized three semantic components. The first component are **situation schemata** which represent situational knowledge in the form of a matrix of abstract participant constellations; the second is the lexical specification of verbs for a **designated participant**, independent of the thematic entailments, and finally a **proto-role representation of thematic information**.

³¹ I omit the attribute ARG-ST for phrases. Its function is taken over by the grammatical function features.

³² The sub-attributes of VAL, that is ‘SUBJ’, ‘COMPS’ take non-empty lists as values at the lexical level, but have empty lists at the points in the phrasal build-up where the valence requirements in question have been satisfied. Having such an attribute in addition to our ‘GF’ would seem unproblematic.

I have demonstrated that these semantic components can be integrated by means of an attribute-value representation of verb meaning. I introduced three main ditransitive situation types, namely TRANSITIONS, PERTINENCE RELATIONS and INDUCTIONS. These semantic types and sub-types thereof allow us to capture the semantics of a variety of ditransitive meanings within a system of ditransitive situation-types. Due to the negative entailment of the Principle of Ditransitive Asymmetry (see section 2), reflected in the disjunctive formulation of the ditransitive situation schemata, we have to leave the feature description of the ditransitive root type open.

I have finally suggested an account of diathesis alternations in terms of ‘**additive phrasal build-up**’, which reflects what Fillmore (1999) calls the ‘syntactic and semantic properties of constructions’.

References

- Abraham, W.(1995)*Deutsche Syntax im Sprachenvergleich. Grundlegung einer typologischen Syntax des Deutschen*. Studien zur Deutschen Grammatik 41. Tübingen: Narr.
- Davis, Anthony R. and J.-P. Koenig (2000) Linking as Constraints on word classes in a hierarchical lexicon. *Language*. 76:56-91.
- Dowty, D.R. (1986) On the Semantic Content of the Notion “Thematic Role”. Paper given at the University of Massachusetts conference in Property Theory, Type Theory, and Semantics.
- Dowty, D.R. (1991) Thematic Proto-Roles and Argument Selection. In *Language* 67, 547-619
- Draye, Luk. (1996) The German dative. in William Van Belle, Willy Van Langendonck *The Dative* Volume 1, Benjamins Publishing Company, Amsterdam.
- Fillmore, Charles. J.(1999) Inversion and Constructional Inheritance. In Webelhuth, Gert, Koenig, J.-P. and Andreas Kathol (eds) *Lexical and Constructional Aspects of Linguistic Explanation..* CSLI Publications
-

- Foley, William and Robert D. Van Valin (1984) *Functional Syntax and universal grammar*. Cambridge: Cambridge University Press
- Ginzburg, Jonathan and Ivan Sag (2000) *Interrogative Investigations*. CSLI Publications
- Goldberg, Adele (1995) *Constructions: A Construction Grammar Approach to Argument Structure*. Chicago: Chicago University Press.
- Heinz, Wolfgang and Johannes Matiassek (1994) Argument Structure and Case Assignment in German. In In Nerbonne, John (eds). *German in Head-Driven Phrase Structure Grammar*. CSLI Publications.
- Kathol, Anreas (1994) Passives without Lexical Rules. In Nerbonne, John (eds). *German in Head-Driven Phrase Structure Grammar*. CSLI Publications.
- Koenig, Jean-Pierre (1999) *Lexical Relations*. CSLI Publications, Stanford Monograph in Linguistics.
- Levin, Beth (1993) *English Verb Classes and Alternations*. Chicago: Chicago University Press.
- Pollard, Carl and Ivan Sag (1994) *Head-Driven Phrase Structure Grammar*. Chicago: Chicago University Press.
- Przepiórkowski, A. (1999). Case assignment and the complement/adjunct dichotomy: A non-configurational constraint-based approach. Ph.D. thesis, University of Tübingen, Germany.
- Sag, Ivan A. and Tom Wasow (1999) *Syntactic Theory: A Formal Introduction*. CSLI Publications.